

What is WipFrag Solo?

WipFrag Solo is a completely automated analysis instrument for measuring the size distribution of unconsolidated material on conveyor belts in real time without disrupting production. This technology is autonomous, portable and performs well in harsh industrial environments for process automation, historical reference or direct control.

How It Works...

When material is present, the camera acquires image samples which are processed onboard. Proprietary edge detection is used to render a polygon network around each particle to instantly generate material specifications such as size distribution, uniformity, shape and more in real time.

Conveyor Belt Configuration

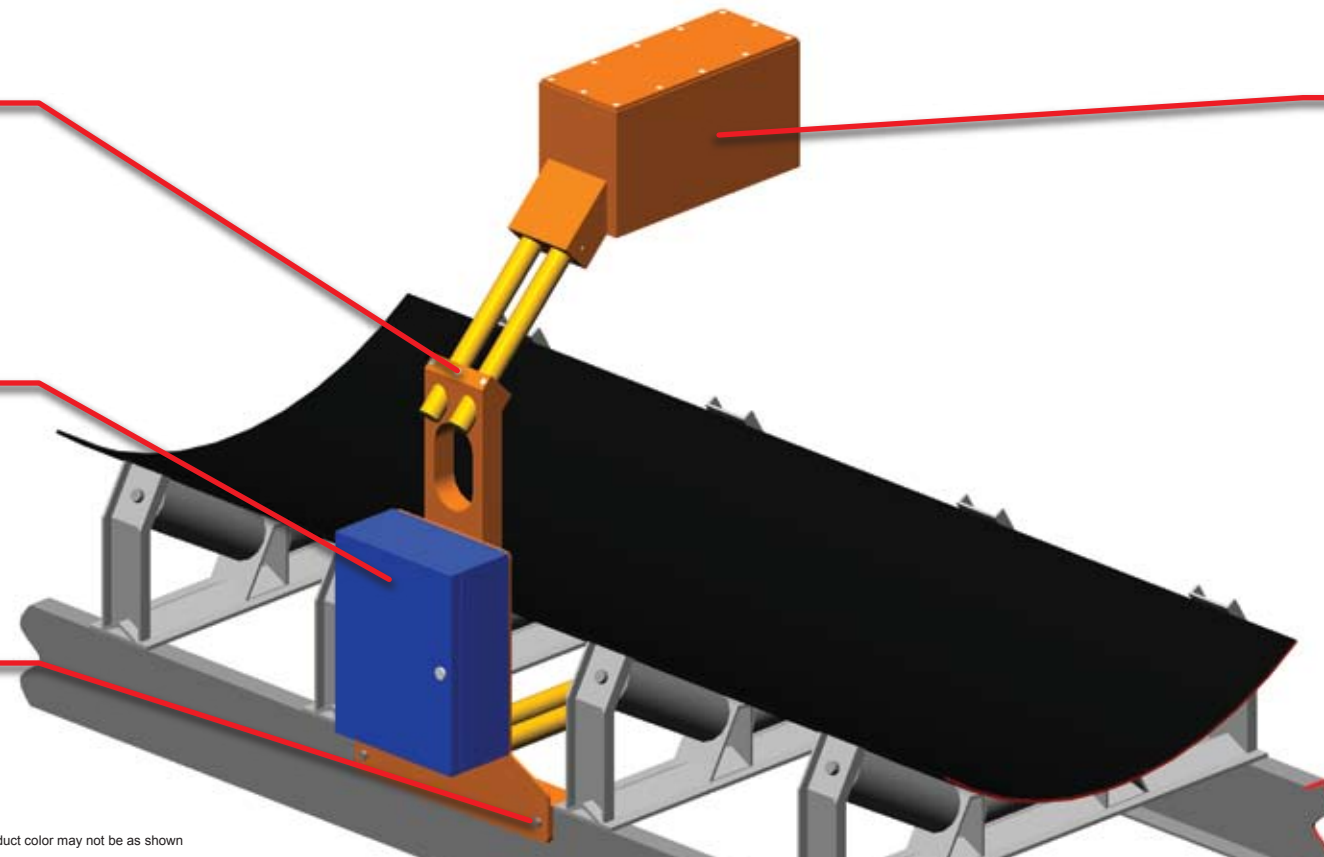

Lightweight frame adjusts to various conveyor belt widths (500-2000mm)

Removeable head unit contains state of the art integrated components

Control box provides easy access to power, signal and data components

WipFrag Solo System Features:

- Portable
- Autonomous (just add power)
- Real time sampling
- High component MTBF*
- Universal power 100-240VAC
- NEMA 4 / IP66 Ingress Protection
- Versatile I/O Connectivity
 - › OPC Client/Server (native)
 - › Modbus, RS232/422/485 (standard)
 - › 0-10V, 4-20mA, TTL, Relay (optional)

Integrated bracket clamps or bolts to stringers in minutes

Product color may not be as shown

The Advantages...

WipFrag Solo automatic granulometry analysis technology is a powerful tool that collects historical data in real time, enables process automation and minimizes the need for manual analysis which can be slow, subjective, disruptive and unsafe.

Benefits include:

- | | | |
|-----------------------------|----------------------------|-------------------------|
| • Non-Contact | • High Accuracy | • Detect Irregularities |
| • Non-Disruptive | • Improve Safety | • Real Time Results |
| • Fully Automated | • Increase Efficiency | • Contamination Alerts |
| • Establish Quality Control | • Increase Throughput | • Reduce Maintenance |
| • Characterize Material | • Objective Quantification | • Reduce Waste |

The Results...

Output Graph/Chart types:

- Granulation Curve & Histogram
- Time Base Strip Chart

Output File types:

- Raster Image (JPG, BMP)
- Vector Image (PDF, WMF)
- Data (DAT, LOG, CSV, XML)

ISO Metric or US Imperial Units

User Defineable Size Classes

